

HYUNDAI Electric Chain Hoist with Motorized Trolley HT SERIES

HYUNDAI HT SERIES FEATURES:

- 🌐 ELECTRO D.C MAGNETIC DISK BRAKE SYSTEM
- 🌐 UPPER & LOWER LIMIT SYSTEM WITH AUTO SLIP CLUTCH DEVICE
- 🌐 ADJUSTABLE LOAD LIMITER FOR OVER-LOAD PROTECTION.
- 🌐 GEAR BOX HEAT TREATED, TWO STAGE REDUCTION GEAR & FIRST STAGE HELICAL GEAR IMMERSSED IN OIL BATH ENSURES QUIET OPERATION AND LONG LIFE.
- 🌐 ALLOYED ALUMINUM CAST HOUSING FRAME WITH SIMPLIFIED CURVED LINE CONTRIBUTES TO EXCELLENT APPEARANCE AND EASY HANDLING LOW HOIST WEIGHT.
- 🌐 SAFETY LOAD CHAIN ASSURES THE SAFE OPERATION WITH INTERNATIONAL AUTHORIZED GRADE MATERIALS.

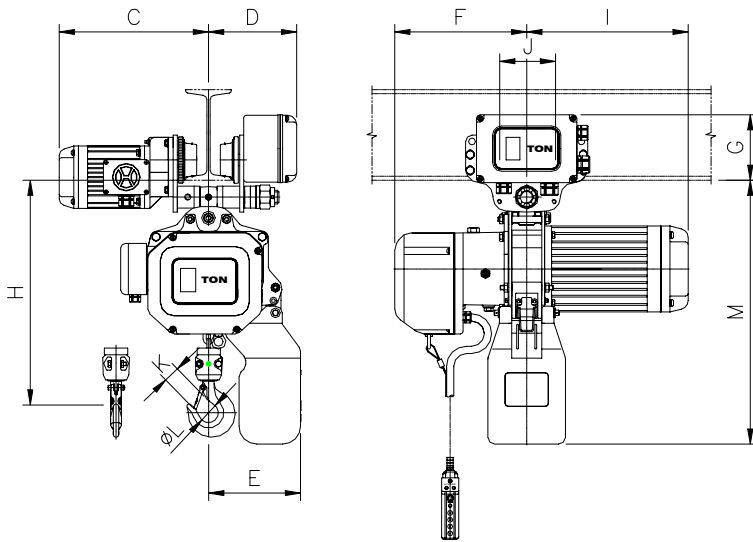

SPECIFICATIONS

Cap (kg)	Model	Lift (M)	Rating (min)	Hoisting Speed		Hoisting Motor (kw)	Trolley Speed (m/min)		Trolley Motor (KW)	Load Chain (dia x falls)	Net Weight (kg.)	Beam Width (mm)	Min. Radius (mm)
				M/Min	F.P.M.		M/Min	F.P.M.					
1000	HT-D100	6	30	3.25/6.5	11/21	1.5/0.75	10	33	0.25	7.1 x 1	100	75 -125	1100
2000	HT-D200	6	30	1.63/3.25	5/11	1.5/0.75	10	33	0.25	7.1 x 2	110	100-150	1200

DIMENSIONS (mm, inches)

Model	C	D	E	F	G	H	I	J	K	L	M
HT-D100	327.5	193.5	203	289.5	145	423	354.5	127	30	38	583.5
	12.89"	7.6"	7.99"	11.39"	5.7"	16.65"	14"	5"	1.18"	1.5"	22.97"
HT-D200	327.5	213	253	289.5	150	620	354.5	159	36	48	657
	12.89"	8.38"	9.96"	11.39"	5.9"	24.4"	14"	6.26"	1.42"	1.89"	25.87"

Western North America's Authorized Dealer:

MUSSELL CRANE MANUFACTURING

P.O. Box 253, 620 B Wellington Avenue, Chilliwack, B.C. Canada V2P-6J1
 Ph: (604) 792-5023 Fax: (604) 792-5038 E-mail: info@musselcrane.com
 Web-site: www.musselcrane.com